

FST930 Bootcamp Base



The Bootcamp Base gives trainers every opportunity they need to do their training. It is a multipurpose gym where you can easily train with groups of more than 10 people. The Bootcamp Base allows users to stow barbells at various heights and to attach boxing bags and many other training equipment (suspension trainers, climbing ropes, battle ropes, elasticated attachments etc.).

Grupa	Siłownie zewnętrzne - plenerowe
Kategoria	Bootcamp Training
Optymalny wiek użytkownika	13 - 16+
Maksymalna wysokość upadku	150
Wysokość (cm)	262
Stęfa bezpieczeństwa	38.4 m2



TRAINING



SUR-
FACE

IN-
GROU.

ASTM



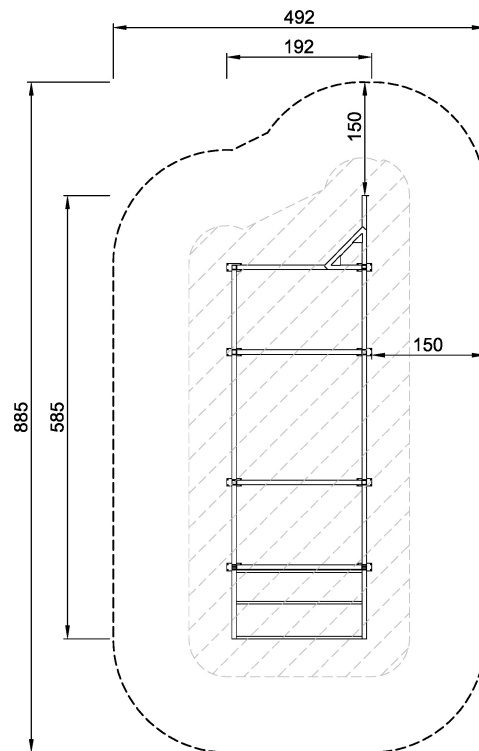

FST93000
*150cm
**260cm
***39.6m²
1:100

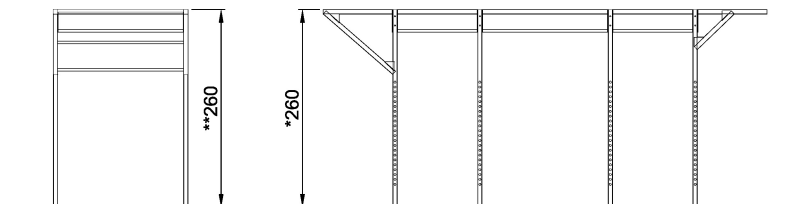

FST93000-xx01
1:100

* = Najwyższy punkt powierzchni użytkowej.
** = Wysokość produktu.

Waga najcięższego produktu	kg.	Liczba osób potrzebnych do montażu	1 Ludzie
Ilość betonu	NaN m ³	Czas montażu	4 Godziny otwarcia
Liczba fundamentów	NaN	Głębokość wykopu	NaN m ³